

HCK

HOW COOL IS THAT?!

BC-130RDA

3.8 cu. ft. single door refrigerator with freezerette



Introducing our retro fridge, featuring innovative features to enhance your experience. With a smart energy-saving system and humidity control technology, this fridge really ensures food safety and freshness. The self-closing hinge design and 180-degree door opening offer convenience, while the anti-vibration technology ensures quiet operation. Plus, with flexible wine shelves and a glass hang shelf design, it offers versatile storage options. Crafted with a one-piece metal shaping process, it combines durability with timeless style.

AVAILABLE COLORS/OPTIONS



Mint Green

Features and Benefits

DOE Energy Efficiency	Energy-efficient design reduces energy consumption, helping you save on electric bills and reduce your carbon footprint.
Sleek rounded corner metal handle	The golden metal handle adds a premium touch, elevating the overall luxury feel of the design.
Stylish retro look with 3D metal logo	The 80° rounded design prevents injuries caused by impact; the logo adds visual appeal.
Multiple interior designs	Provide flexible storage options, making it easy to organize and store items.
7 level temperature adjustment	Allows you to adjust the temperature precisely, catering to different food and beverage storage needs.
TPE material	Environmentally friendly TPE material features anti-bacterial and anti-mold properties, ensuring hygiene and safety.
Anti-vibration system, quiet operation	Shock absorption and noise reduction enable you to place it in any room in the home.
Sliding shelves	The thickened tempered glass shelf offers sturdy and durable storage support, ensuring safety.
Digital controller	For accurate and easy temperature control.
Modern black metal interior	Features anti-bacterial and anti-mold properties, ensuring hygiene and safety in food storage.
Adjustable legs	Make it easy to change the height of the appliance, ensuring stability and adaptability to different floors.
Warranty	1 year parts and labor.
ETL/CETL Sanitation certified for safety	Ensures the highest standards of safety and sanitation for your peace of mind.

3.8 cu. ft. single door refrigerator with freezerette

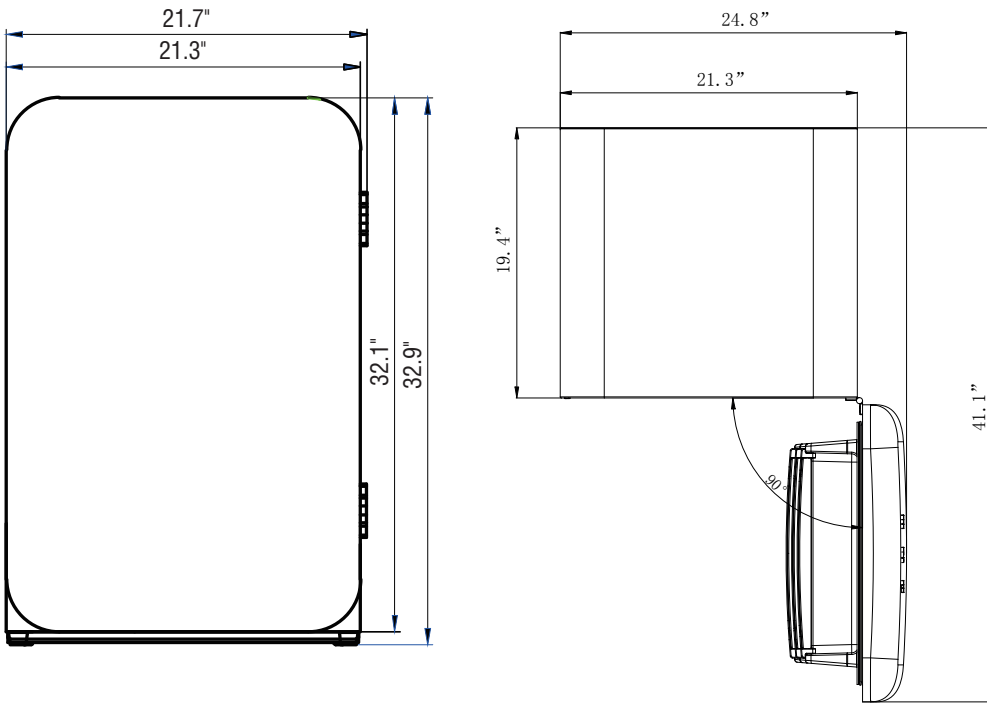

Specifications

Dimensions W x D x H	21.7 × 23 × 32.9"	Net Weight	70.5lbs
Climate Rating	Tropic	Noise Level	39dB
Cooling System	Static	Compressor	Constant speed
Control System	Mechanical	Refrigerant type	R600a
Power Supply	110V / 60Hz / 1A	Glass Shelves	2
Total Net Volume	3.8 cubic feet	Wine/Bottle Shelf	1
Fresh Food Net Volume	3.2 cubic feet	Door Shelves	3
Freezer Food Net Volume	0.6 cubic feet	Crispers	1
Electrical Cord Length	5.9 feet	Annual Energy Co	248kWh/year
		Temperature range	Fridge 32 to 50° F Freezer -13° to -5° F

HCK is a leading provider of premium refrigeration solutions, specializing in Beverage Fridges, Retro Fridges, Outdoor Refrigerators, Wine Coolers, Ice Makers and Kegerators. Their products seamlessly blend stunning design with cutting-edge technology, catering to both consumer and commercial customers around the world. Whether you're a wine enthusiast seeking a dual-zone wine fridge, a homeowner looking for an undercounter beverage outdoor refrigerator, or a business owner in need of an iconic wine cooler, HCK delivers reliable cooling solutions to elevate your lifestyle and enhance your kitchen experience.

Email: info@hcknorthamerica.com
Web: www.hcknorthamerica.com
Tel: 855-478-4203

Models may be subject to modification without prior notice. We reserve the right to make, at anytime, changes deemed necessary to improve products.



HCK

HOW COOL IS THAT?!

